

5.18^{SMART}



Maximum lifting height: 17.56 m
Maximum reach: 14.26 m
Electronically controlled hydrostatic transmission
Automatic levelling device
Pivoting stabilisers

The data given in this brochure are provided for information purposes and are subject to change without prior notice

REV08-A

RTH 5.18 SMART

MACHINE MODEL	Rotary telescopic handler	RTH 5.18 SMART	
	Maximum lifting capacity	4.999 kg (centre of gravity 500 mm)	
	Maximum lifting height	17.56 m	
	Rotation	360° (continuous)	
ENGINE	Type	Deutz TCD 3.6 L4 - stage IV	Deutz TCD 3.6 L4 EDG - stage III A compliant
	Rated Power	100 kW - 134 hp @ 2,200 rpm	100 kW - 134 hp @ 2,200 rpm
	Maximum torque	500 Nm @ 1,600 rpm	500 Nm @ 1,600 rpm
	Displacement	3,6 l	3,6 l
	Cylinders	4 in line	4 in line
	Fuel	Turbocharged direct injection diesel	Turbocharged direct injection diesel
	Cooling System	Water - intercooler	Water - intercooler
TRANSMISSION	Type	Hydrostatic	
	Model	Bosch - Rexroth	
	Maximum pressure	500 bar	
	Displacement	Electronically controlled variable displacement pump Variable displacement motor	
	Gearbox	Dropbox, 2 speeds forward-reverse	
AXLES AND BRAKES	Type	Axles with planetary gearboxes	
	Rear axle	Steering	
	Front axle	Oscillating and steering with levelling +/-10°	
	Service brake	Hydraulically operated wet multi-disk brakes on each axle	
	Parking brake	Hydraulic with negative action	
Tyre sizes	445/65 R22,5		
PERFORMANCE	Max. travel speed	40 km/h	
	Drawbar pull	66 kN	
	Gradeability	44%	
	Turning circle (at forks)	5,870 mm	
WEIGHTS	Total unladen	15,630 kg	
	Front axle unladen (boom retracted and lowered)	7,600 kg	
	Rear axle unladen (boom retracted and lowered)	8,700 kg	
TANK AND SYSTEM CAPACITIES	Diesel fuel tank	180 l	180 l
	AdBlue	10 l	N/A
	Hydraulic fluid	190 l	190 l
	Engine oil	8 l	8 l
	Coolant	20 l	20 l
HYDRAULIC CIRCUIT FOR MOVEMENTS	Max. working pressure	350 bar	
	Circuit type	Load sensing	
	Service pump	Bosch Rexroth - Variable displacement	
	Distributor for boom and turret movements	Danfoss - SIL 2 electro-proportional valve	
	Distributor for stabilisers	Bosch Rexroth - Electro-hydraulic actuators	
	Movements control	2 no. two-axis Danfoss joysticks with deadman safety device Managed via CAN bus	
STANDARDS MET	EN 13849: concerning the safety of all machine controls EN 13000: concerning standards for hydraulic cranes EN 280: concerning standards for mobile elevating work platforms FOPS/ROPS EU 2016/1628: concerning engine emissions standards EN 1459-2: concerning standards for slewing variable-reach trucks		

The data given in this brochure are provided for information purposes and are subject to change without prior notice

REV08.A

SECTORS OF USE

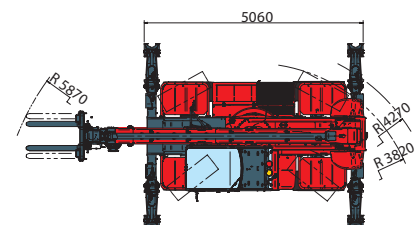
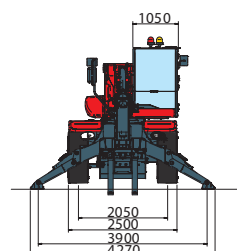
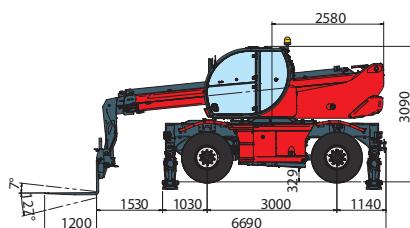
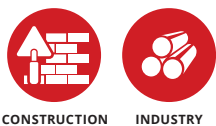

Magni Telescopic Handlers srl

Via Magellano, 22 - 41013 Castelfranco Emilia, Modena, Italia - Tel: +39 059 8630811 - Fax: +39 059 8638012
 commerciale@magnith.com - www.magnith.com

J 2000

JIB 2,000 kg

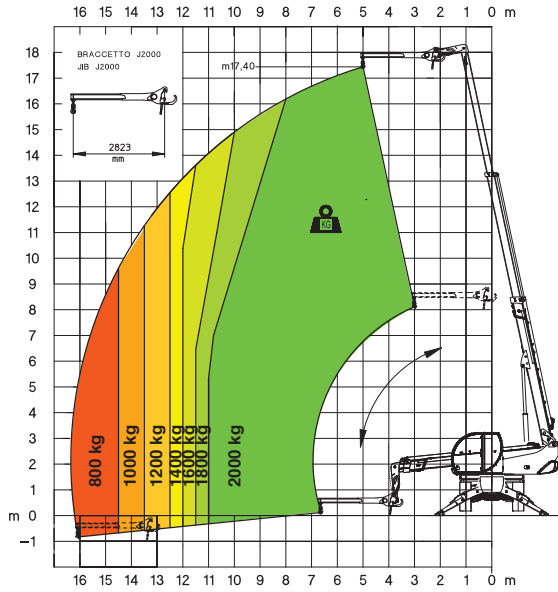

REP 2-4,5

ROTATING EXTENDABLE BASKET 500 kg

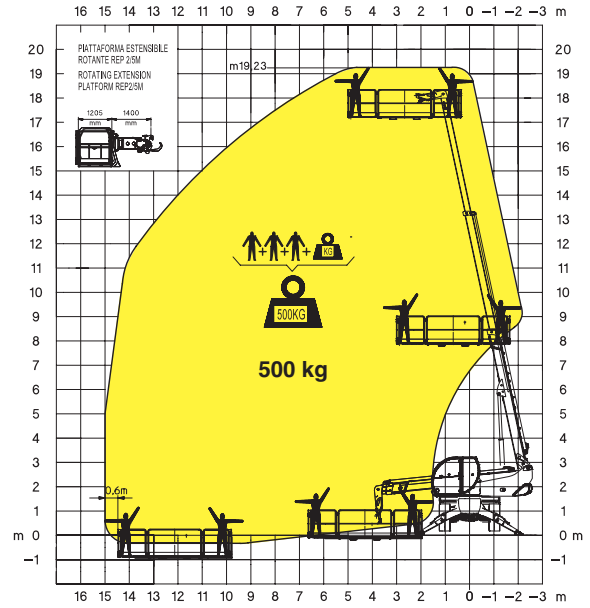

REP 10.2-4,7

ROTATING EXTENDABLE BASKET 1,000 kg

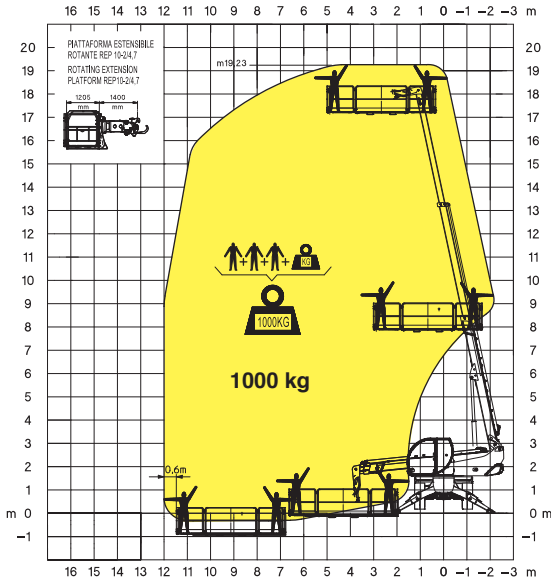

TP

TELESCOPIC PIVOTING BASKET WITH 180° ROTATION

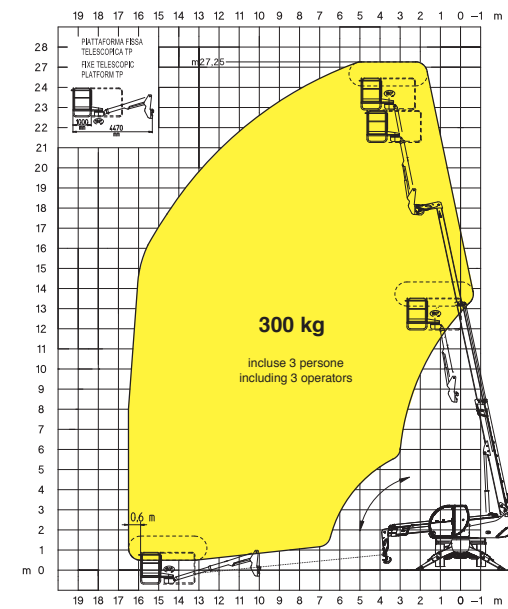

TP O-U

TELESCOPIC PIVOTING OVER-UNDER BASKET WITH 340° ROTATION

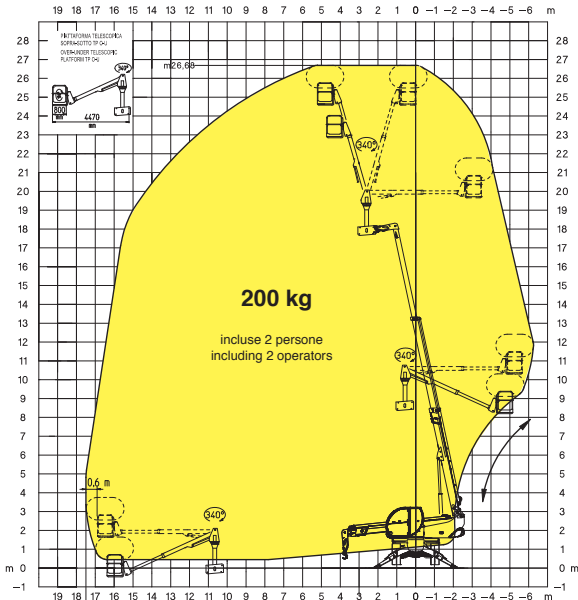

TP O-U

TELESCOPIC PIVOTING OVER-UNDER BASKET WITH 340° ROTATION

