

YT193, 4x2 Technical specification

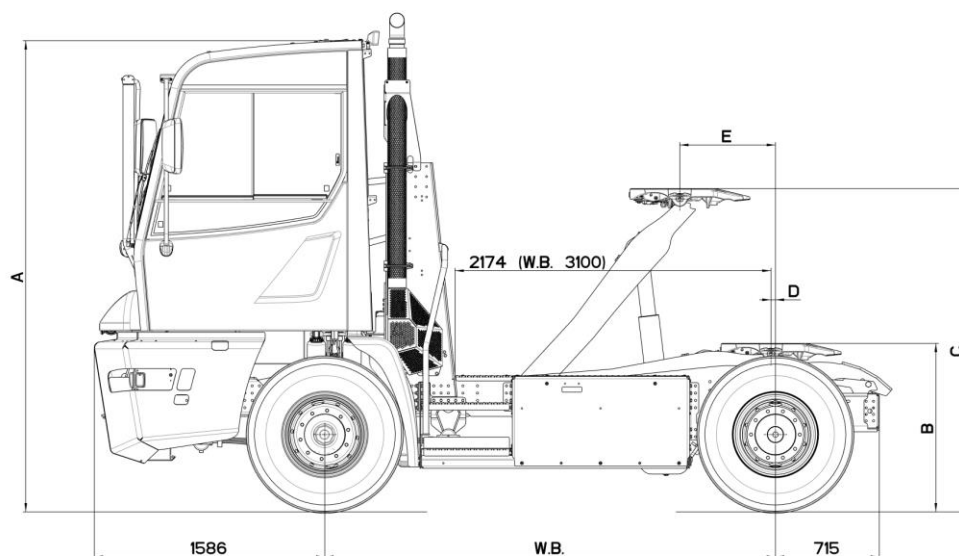
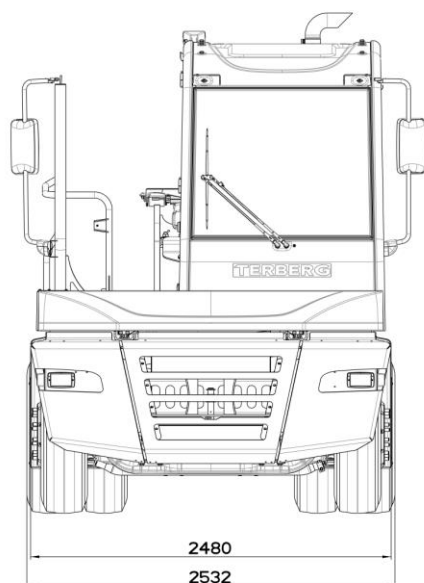

Tyres	Wheelbase	Cylinder stroke (mm)	A ±15mm	B * ±15mm	C * ±15mm	D ±5mm	E ±5mm
295/60R22.5	31/33/3500	425	3164	935	1582	15	202
		545		1124	1922	41	436
		830		935	2131	15	658
11R22.5	31/33/3500	425	3227	1129	1645	31	202
		545		1187	1985	41	436
		830		1129	2194	31	658
13R22.5	31/33/3500	425	3265	1196	1683	36	202
		545		1225	2023	41	436
		830		1196	2232	36	658

*Based on TTA70-11 rear axle with air suspension without mudguard

ENGINE

Cummins B6.7-173 (Tier 4f/Stage V)

Six-cylinder four-stroke direct injection diesel engine with variable geometry turbo charging and intercooler.

Engine equipped with engine brake.

Engine equipped with Cummins single module exhaust system including DOC, DPF and SCR-catalyst with AdBlue injection.

Displacement:6,7 dm³

Bore: 107 mm

Stroke: 124 mm

Output:... 142 kW (190 hp) at 1800 rpm

Torque:.....881 Nm at 1300 rpm

Maximum speed.....1800 rpm

Acc. to ECE R120

Optional:

Only for use outside EU/US/Canada:

- Cummins QSB6.7-173 (Tier 3)

GEARBOX

Allison, type 3000

Automatic shift transmission with 6 gears forward, 1 gear reverse and torque converter equipped with Lock-Up clutch. Including standard F/R shift protection.

Gear ratio's	theoretical speed (1800rpm) [km/h]
3.487	8 (F1)
1.864	15 (F2)
1.409	20 (F3)
1.00	29 (F4)
0.75	38 (F5)
0.65	44 (F6)
5.027	6 (R)

Note: speed is 37km/h@1500 engine rpm (Tyre size 11R22.5, axle ratio 11.98:1)

Optional:

ZF, type 6WG191 (without Lock-Up)*

- Powershift transmission with high efficiency torque converter and 6 gears forward and 3 gears reverse.

* Only i.c.w. rear axle ratio ≥12.17:1

FRONT AXLE

Volvo FA8.2

Non-driven steering axle

Capacity 11.000 kg (20 km/h)*

* Actual axle load capacity depending on tyre load rating.

REAR AXLE

Terberg TTA type 70-11

Capacity 30.000 kg (at 20 km/h)*

Hub reduction axle with total reduction ratio 11.98:1

Optional:

- TTA 70-01 9.49:1
- TTA 71-xx 10.0:1, 12.17:1 or 16.22:1
- D81PL478 9.72:1, 12.73:1 or 16.13:1
- D81 PL477 13.2:1 or 16.36:1

* Actual axle load capacity depending on tyre load rating.

SUSPENSION

Front: Parabolic leaf springs in rubber mountings with 2 telescopic shock absorbers.

Maintenance-free system.

Rear: Directly bolted to chassis frame.

Optional:

- Air suspension with rubber stops

RIMS AND TYRES

Tyres: 11R22.5 (6 pieces)

Rims: 10 stud disc wheels 22.5 x 8.25

STEERING SYSTEM

Fully hydrostatic orbitrol steering system with priority valve and double acting steering cylinder.

Emergency steering functionality.

Steering wheel diameter 350 mm.

Turning circle over front bumper (m)

	45°	50°
WB 3100	13,7	13,0
WB 3300	14,3	13,5
WB 3500	14,8	14,0

Note: 50° not possible icw 310/80R22.5, 315/80R22.5, 13R22.5 and 10/11/12.00R20 tyres.

5th WHEEL**Terberg 2" cast steel plate**

Technical capacity 36.000 kg.

Lifting capacity 36.000 kg*.

Automatic locking of jaw system.

Pneumatic unlocking of 5th wheel operated from cabin.

Indicator light for positive locking inside the cabin.

* Actual lifting capacity depending on rear axle choice, tyre load ratings and 5th wheel height.

HYDRAULIC SYSTEM

Engine driven hydraulic pump for steering and lifting/lowering 5th wheel plate, directly mounted to the engine, with priority valve for the steering system.

Hydraulic oil tank protected mounted to the chassis frame. Tank capacity 33 dm³.

Hydraulic valve electronically operated from inside the cab to lift/lower/hold the 5th wheel. Working pressure 230 bar.

2 heavy-duty double acting hydraulic lift rams in 3 different stroke variants:

- 425mm single stage.
- 545mm single stage.
- 830mm double stage.

CHASSIS

Combination of heavy duty welded construction with bolted front end.

Air reservoirs and fuel tank protected mounted to the chassis, access steps with anti-slip surface integrated in chassis.

Towing pin attachment at front and rear of chassis.

BRAKE SYSTEM

Full air brake system with split front and rear axle and parking brake circuits. Parking brake working on rear axle.

TTA rear axles equipped with S-cam brake.

Kessler rear axles with simplex wedge brake (D81PL478) or single jaw disc brake (D81PL477).

All axles equipped with auto slack adjusters.

Brake pressure: 7,8 - 8,5 bar.

Air reservoirs: 3 x 37 dm³ with standard air dryer.

2-line trailer brake system mounted on rear side of cabin, with yellow and red spiral hoses with glad-hands.

FUEL TANK

Capacity 290 dm³.

COOLING SYSTEM

Plate and bar type radiator of heavy-duty construction mounted on rubber silent blocks with separate air to air transmission oil cooler and engine intercooler all mounted side by side.

EXHAUST

Outlet with vertical pipe. Exhaust system in critical area's protected with stainless steel grille.

ELECTRICAL SYSTEM

24 Volt negative earth.

Alternator : 28V/95A

Batteries : 2 x 12 Volt / 140 Ah

Output starter : 7,8 kW

Fuses and relays mounted in central electrical box. Can-Bus system allowing multiple options/flexibility and easy fault tracing.

Wiring with code numbers and easy readable/visible/accessible mounted in central electrical box.

7 pin SAE socket at rear of cab for trailer connection (DIN ISO 1185).

LIGHTING

H4 head lights with dipped and main beam and separate direction indicators.

LED rear lights on rear of chassis, with direction indicators and brake lights.

5th wheel LED flood light behind cabin.

Double interior light in cabin.

Mounting for rotating beacon light.

CABIN

High comfort - 1 person - left hand or right hand drive position.

Forward facing driver's position.

Dimensions outside:

- width : 1420 mm
- length : 1625 mm
- height : 1860 mm

Cabin construction of strong steel profiles. Fully tested and certified according to ROPS ISO 3471:2008 and FOPS ISO 3449:2005 standard, while still offering optimum visibility all around.

Cab mounted on 2 anti-vibration mounts at the front and 2 coil-spring suspension/shock absorber units at the rear. Cabin can be tilted with hydraulic hand pump to 72°. Double hydraulic cabin lock.

Entrance to cab by inboard door for safe and easy entrance/exit to/from driver's position.

Double horizontal sliding window at driver's side

Large windows to provide excellent all around visibility.

All window panes tinted hardened safety glass except front window which is layered.

Noise insulation exceeds international standards.

Driver's seat with air suspension and fully adjustable, mounted on console with generous storage space.

Demister/heater with variable speed blower and well positioned air outlets.

Fixed steering column with 1 brake pedal and 1 accelerator pedal, mounted at right side of column.

Dashboard switches:

- Ignition
- Hazard lights
- Lighting

Seat console:

- 5th wheel raise-lower
- 5th wheel unlocking (2x)
- D-N-R
- Work light rear

Driver Information Module:

Multifunctional 5" full colour CAN-bus display (DIM) with:

- Great readability.
- Latest generation HMI with very intuitive menu navigation.
- Easy possibility to read out running hrs and mileage.
- Indicator lights, visual warnings and adjustable audio warnings.
- Very extensive and fully integrated and easy to use diagnostic functionality and SW update facility.
- Vehicle history storage which can be shown on the screen and downloaded via USB.

Steering column:

- Combi switch for:
 - * Direction indicators
 - * Wiper front
 - * High/Low beam
 - * Horn