

YT203-EV, 4x2 Technical specification

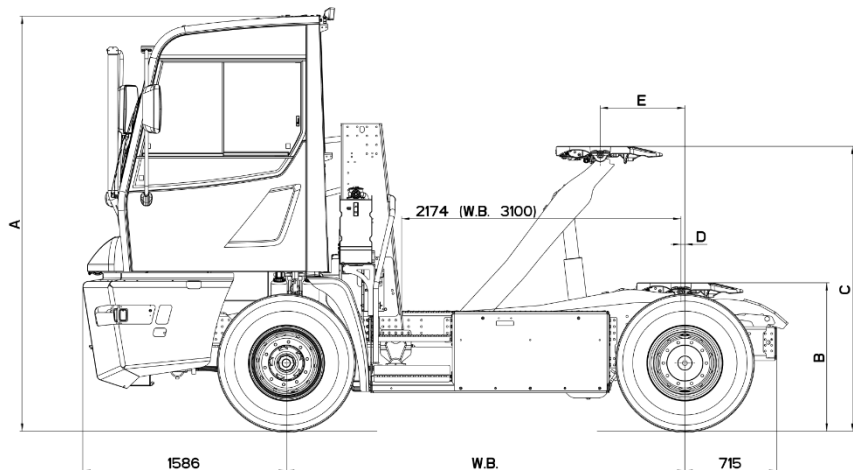
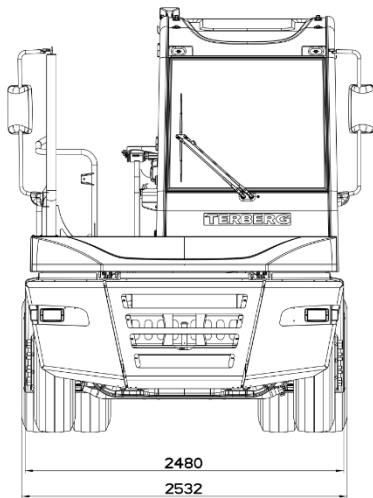

Tyres	Wheelbase	Cylinder stroke (mm)	A ±15mm	B * ±15mm	C * ±15mm	D ±5mm	E ±5mm
295/60R22.5	31/3500	425	3164	925	1572	15	202
		545		1114	1912	41	436
		830		925	2121	15	658
11R22.5	31/3500	425	3227	1119	1635	31	202
		545		1177	1975	41	436
		830		1119	2184	31	658
13R22.5	31/3500	425	3265	1186	1673	36	202
		545		1215	2013	41	436
		830		1186	2222	36	658

* Based on TTA71 rear axle with air suspension without mudguards

TRACTION MOTOR

ZF Cetrax

Asynchronous oil cooled E-motor with planetary reduction (ratio 3.36:1) combined with well-matched Inverter + dedicated control-ECU.
 Peak power (max. 1 min): 200 kW
 Peak torque (max. 1 min)4500 Nm
 Power (max. 30 min): 170 kW
 Torque (max. 30 min)2170 Nm

BATTERY PACKS

Terberg designed battery pack using NMC cells and equipped with fluid operated temperature conditioning system to allow operation in all climates.
 Electric driveline (including Battery packs) certified to ECE R100

3100mm WB:

Standard battery pack setup:

Capacity:..... 2x 48kWh = 96 kWh
 Nominal Voltage: 654 V

Optional:

Capacity:..... 3x 48kWh = 144 kWh
 Nominal Voltage: 654 V

3500mm WB:

Standard battery pack setup:

Capacity: 2x 74kWh = 148 kWh
 Nominal Voltage: 666 V

Optional:

Capacity: 3x 74kWh = 222 kWh
 Nominal Voltage: 666 V

BATTERY CHARGER

Charging the vehicle is possible with every charger that fulfils the CCS2.0 charging standard. Detailed charger requirement information can be provided.
 Charger capacity:.....24-150 kW*
 Charger type: CCS2.0

*Depending on installed battery capacity

FRONT AXLE

Volvo FA8.2

Non-driven steering axle
 Capacity 11.000 kg (20 km/h)*
 * Actual axle load capacity depending on tyre load rating.

REAR AXLE

Terberg TTA type 71-08

Capacity 38.000 kg (at 20 km/h)*
 Hub reduction axle with total reduction ratio 12.17:1

Optional:

- TTA 71-07 10.00:1
- TTA 71-09 16.22:1

* Actual axle load capacity depending on tyre load rating.

SUSPENSION

Front: Parabolic leaf springs in rubber mountings with 2 telescopic shock absorbers.
 Maintenance-free system.
Rear: Air suspension with rubber stops

RIMS AND TYRES

Tyres: 11R22.5 (6 pieces)
Rims: 10 stud disc wheels 22.5 x 8.25

STEERING SYSTEM

Fully hydrostatic orbitrol steering system with priority valve and double acting steering cylinder.

Emergency steering functionality.

Steering wheel diameter 350 mm.

Turning circle over front bumper (m)

45° 50°

WB 3100 13,7 13,0

WB 3500 14,8 14,0

Note: 50° not possible icw 310/80R22.5, 315/80R22.5, 13R22.5 and 10/11/12.00R20 tyres.

5th WHEEL

Terberg 2" cast steel plate

Technical capacity 36.000 kg.

Lifting capacity 36.000 kg*.

Automatic locking of jaw system.

Pneumatic unlocking of 5th wheel operated from cabin.

Indicator light for positive locking inside the cabin.

* Actual lifting capacity depending on rear axle choice, tyre load ratings and 5th wheel height.

HYDRAULIC SYSTEM

Brushless E-motor driven fixed displacement pump for steering and 5th wheel lifting/lowering, with priority valve for steering system. Oil tank mounted behind cabin.

Oil tank capacity..... 60 liter

Pump capacity:..... 0-60ltr/min

Hydraulic valve electronically operated from inside the cab to lift/lower/hold the 5th wheel. Working pressure 230 bar.

2 heavy-duty double acting hydraulic lift rams in 3 different stroke variants:

- 425mm single stage.
- 545mm single stage.
- 830mm double stage.

CHASSIS

Combination of heavy duty welded construction with bolted front end.

Air reservoirs and fuel tank protected mounted to the chassis, access steps with anti-slip surface integrated in chassis.

Towing pin attachment at front and rear of chassis.

BRAKE SYSTEM

EBS air brake system offering maximum retardation and energy recuperation.

Air supply by E-motor driven 2-cylinder compressor and air dryer with integrated pressure regulator and 4-circuit protection valve.

Parking brake working on rear axle.

Volvo front axle with Z-cam brakes.

TTA rear axle equipped with S-cam brakes.

All axles equipped with auto slack adjusters.

Brake pressure: 7,8 - 8,5 bar.

Air reservoirs: 3 x 37 dm³.

2-line trailer brake system mounted on rear side of cabin, with yellow and red spiral hoses with glad-hands.

COOLING SYSTEM

Side by side plate and bar type radiator of heavy-duty construction mounted on rubber silent blocks. Thermal Management System (TMS) for optimized energy usage.

ELECTRICAL SYSTEM

28 Volt negative earth

DC/DC converter..... 200 A / 28 V

Battery..... 2 x 12 V / 140 Ah

Fuses and relays mounted in central electrical box. Can-Bus system allowing multiple options/flexibility and easy fault tracing.

Wiring with code numbers and easy readable/visible/accessible mounted in central electrical box.

7 pin SAE socket at rear of cab for trailer connection (DIN ISO 1185).

LIGHTING

LED head lights with dipped and main beam and separate direction indicators.

LED rear lights on rear of chassis, with direction indicators and brake lights.

5th wheel LED flood light behind cabin.

Double interior light in cabin.

Mounting for rotating beacon light.

CABIN

High comfort - 1 person - left hand or right hand drive position.

Forward facing driver's position.

Dimensions outside:

- width : 1420 mm
- length : 1625 mm
- height : 1860 mm

Cabin construction of strong steel profiles. Fully tested and certified according to ROPS ISO 3471:2008 and FOPS ISO 3449:2005 standard, while still offering optimum visibility all around.

Cab mounted on 2 anti-vibration mounts at the front and 2 coil-spring suspension/shock absorber units at the rear. Cabin can be tilted with hydraulic hand pump to 72°. Double hydraulic cabin lock

Entrance to cab by inboard door for safe and easy entrance/exit to/from driver's position.

Double horizontal sliding window at driver's side

Large windows to provide excellent all around visibility.

All window panes tinted hardened safety glass except front window which is layered.

Noise insulation exceeds international standards.

Driver's seat with air suspension and fully adjustable, mounted on console with generous storage space.

Blower/heater with variable speed blower and well positioned air outlets.

Fixed steering column with 1 brake pedal and 1 accelerator pedal, mounted at right side of column.

Dashboard switches:

- Ignition
- Hazard lights
- Lighting

Seat Console:

- 5th wheel raise-lower
- 5th wheel unlocking (2x)
- D-N-R
- Work light rear

Driver Information Module:

Multifunctional 5" full colour CAN-bus display (DIM) with:

- Great readability.
- Latest generation HMI with very intuitive menu navigation.
- Easy possibility to read out running hrs and mileage.
- Indicator lights, visual warnings and adjustable audio warnings.
- Very extensive and fully integrated and easy to use diagnostic functionality and SW update facility.
- Vehicle history storage which can be shown on the screen and downloaded via USB.

Steering column:

- Combi switch for:
 - * Direction indicators
 - * Wiper front
 - * High/Low beam
 - * Horn